



1.

MKP X2

2.

3.

MKP(X2) CQC UL CUL NEMKO FIMKO SEMKO
 DEMKO SWISS 275VAC),UL CUL (250VAC,305VAC)

4

5

		$4.3U_{R(DC)}(2S)$ $2000VAC(5S)$	
4		C R (500VDC)	
5		$\pm 10\%$ K $\pm 20\%$ M	
6		$^{-4}(10KHz)$ C $^{-4}$ 10KHz	



7			
		±5%	
		IR 50%	
			±8
		IR 50%	
			±5%
		IR 50%	

8

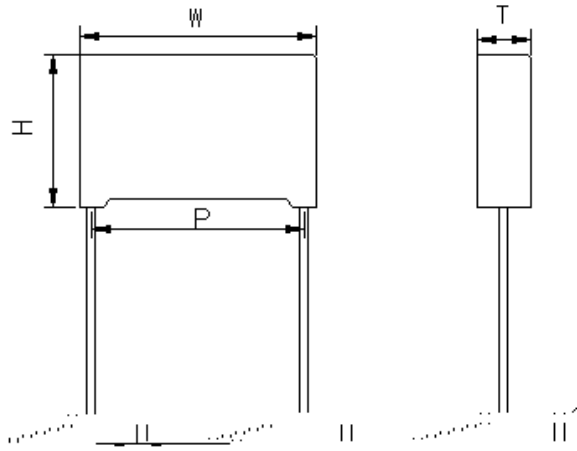

9

	VAC	Dimensions mm				
		W 0.5	H 0.5	T 0.5	P±1	d
0.01		13	11	5	10	0.6
0.015		13	11	5	10	0.6
0.022		13	11	5	10	0.6
0.033		13	12	6	10	0.6
0.047		18	11	5	15	0.8
0.068		18	12	6	15	0.8
0.1		18	12	6	15	0.8

275 (305)



0.33		18	14.5	8.5	15	0.8
0.47		18	16	10	15	0.8
0.47		26.5	16.5	7	22.5	0.8
0.68		26.5	17	8.5	22.5	0.8
1.0		26.5	19	10	22.5	0.8
